

Z:\0000 PROJECT DRAWING FILES\T - Y PROJECTS\TAKE 5 SEFFNER FL BASE 052919.DWG

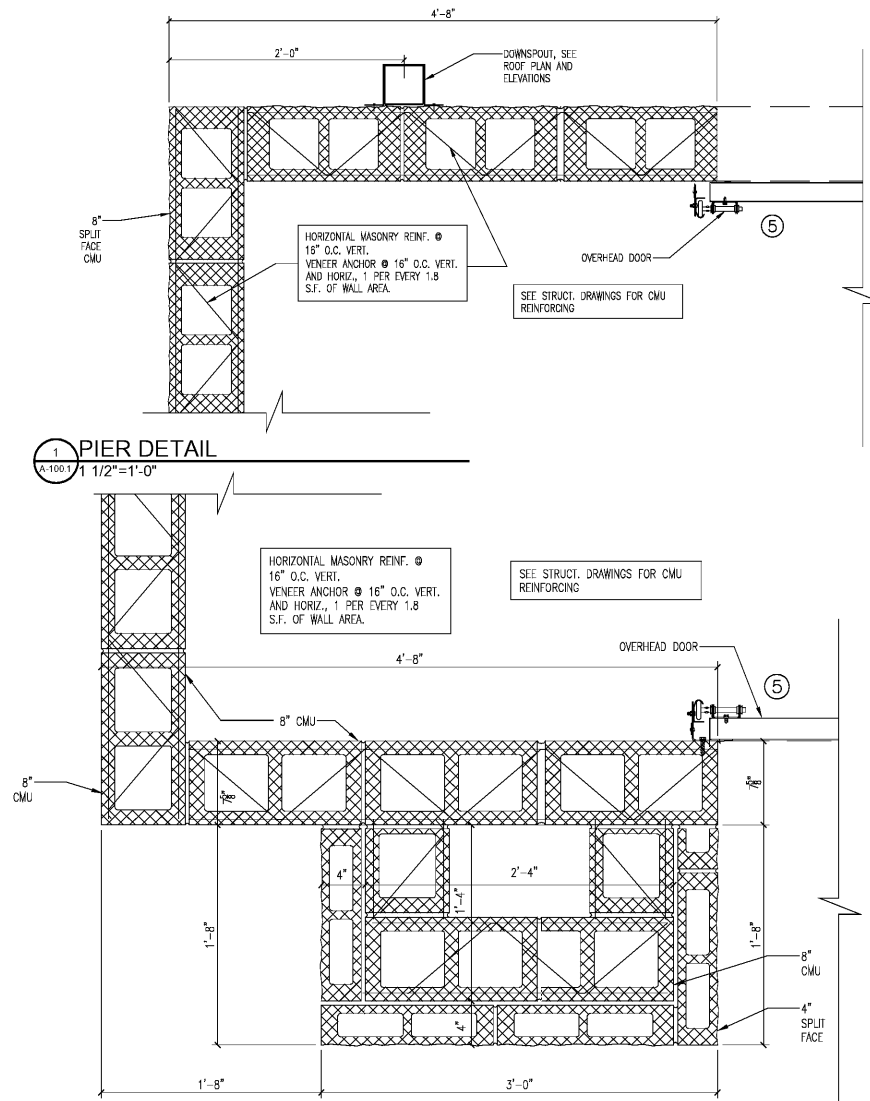

1 PIER DETAIL
A-100.1 1/2"=1'-0"

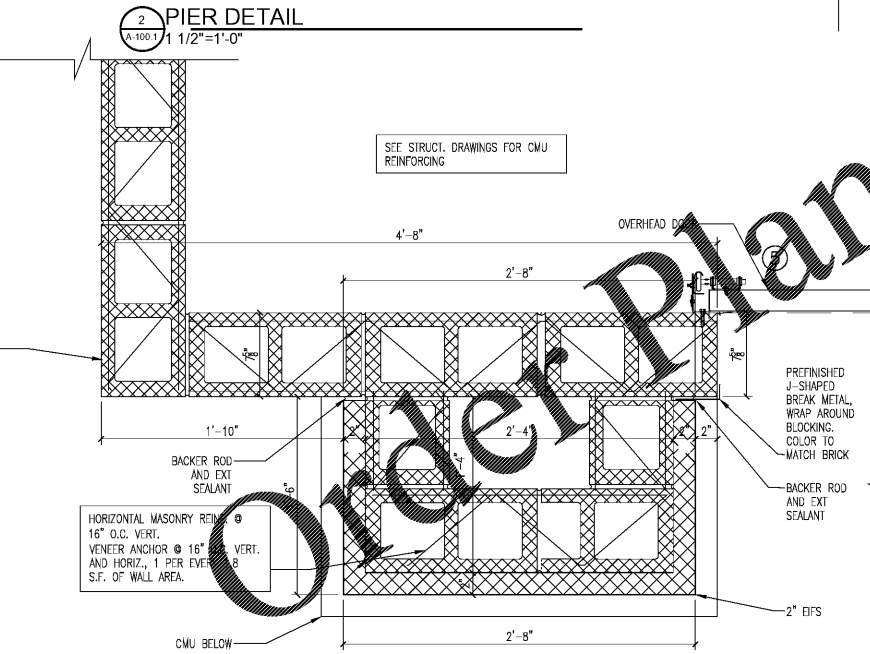

2 PIER DETAIL
A-100.1 1/2"=1'-0"

3 PIER DETAIL
A-100.1 1/2"=1'-0"

1 1/2" EIFS TO CONSIST OF A "STOJIT" FINISH COAT OVER A "STO BIS PLUS" BASE COAT ON REINFORCING MESH ON 1 1/2" ADHESIVE APPLIED FLAT INSULATION BOARD OVER A "STO GUARD GOLD" WATER RESISTIVE BARRIER OVER EXTERIOR PLYWOOD OR OSB SHEATHING. (SYSTEM TO COMPLY WITH ICC ES REPORT "ESR-1748")

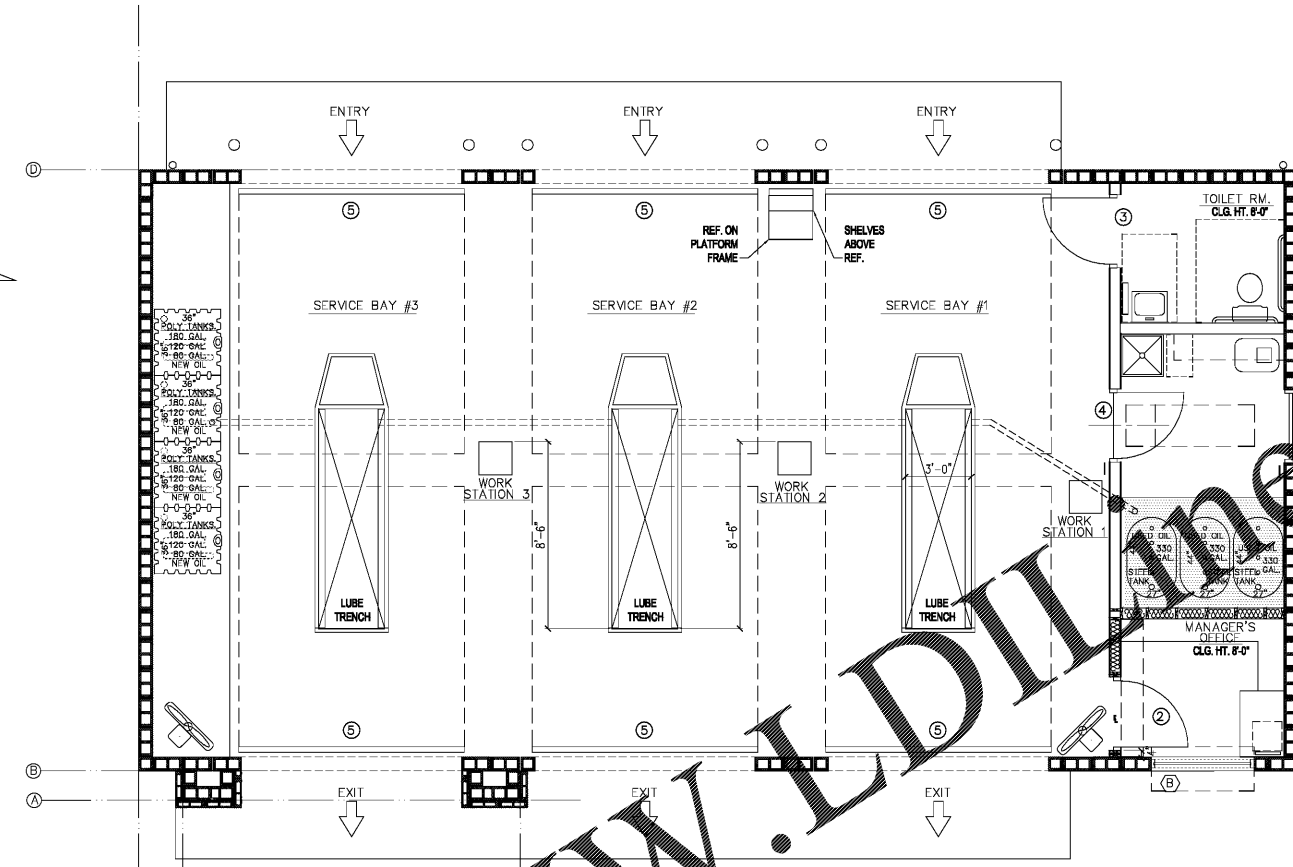

8 EQUIPMENT PLAN
A-100.1 1/4"=1'-0"

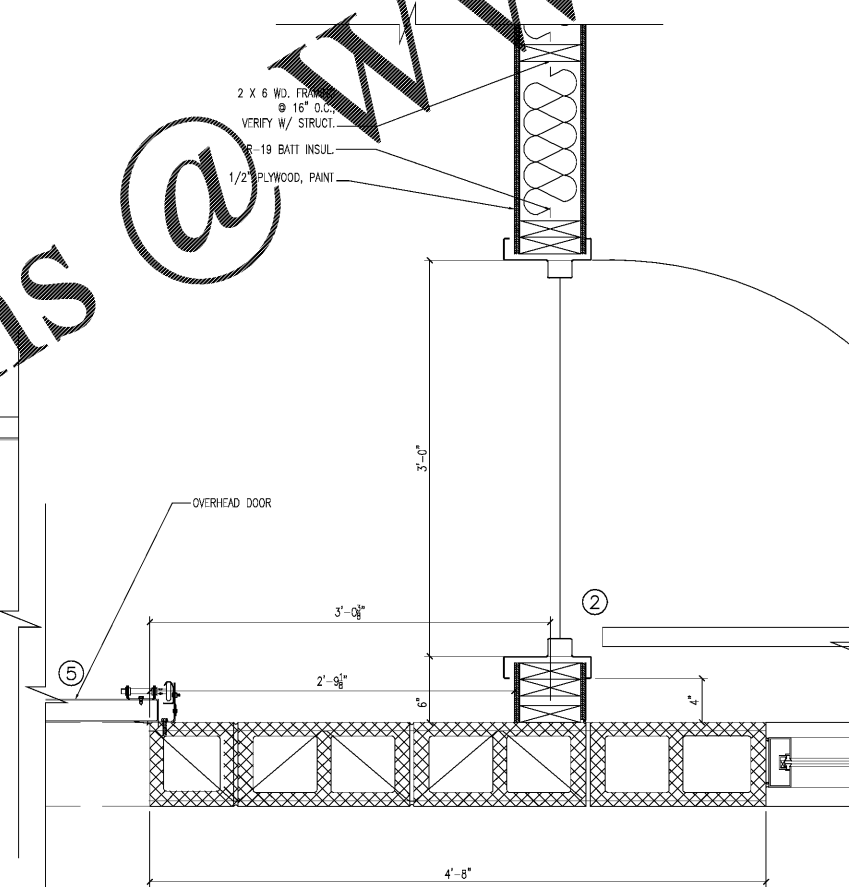

4 PIER DETAIL
A-100.1 1/2"=1'-0"

OFFICE FINISH SCHEDULE				
MARK	FINISH	MFR	MFR #	COLOR
FLOOR				
F-1	SEALED CONC.	WILSONART	4595K-52	BAHIA GRANITE
CEILING				
C-1	ACT	WILSONART	4595K-52	
BASE				
B-1	VINYL	WILSONART	4595K-52	
WALLS				
W-1	PAINT	WILSONART	4595K-52	

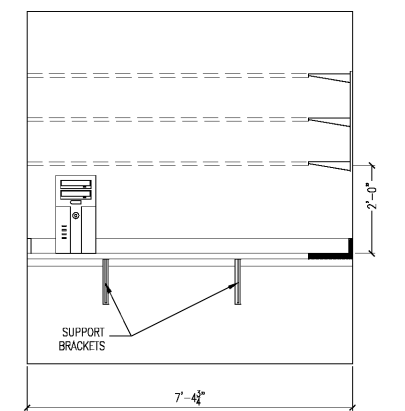

5 OFFICE ELEVATION
A-100.1 1/2"=1'-0"

PLASTIC LAMINATE SPECS			
LOCATION	MANUF.	NUMBER	NAME
COUNTERTOP	WILSONART	4595K-52	BAHIA GRANITE

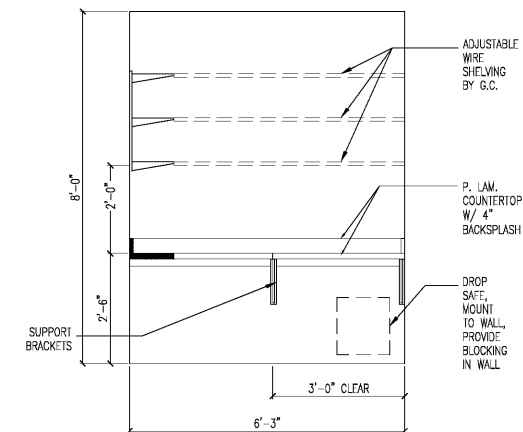

6 OFFICE ELEVATION
A-100.1 1/2"=1'-0"

7 OFFICE ELEVATION
A-100.1 1/2"=1'-0"

TAKE 5 OIL CHANGE
11909 E. MLK JR BLVD
SEFFNER, FL 33584

FOR:
TAKE 5 OIL CHANGE / DRIVEN BRANDS
CHARLOTTE NC

1315 KENNEDY BLVD, SUITE 110
CHARLOTTE, NORTH CAROLINA, NC 28203
PHONE: 704.370.6699 FAX: 704.370.6676
www.childreyrobinson.com

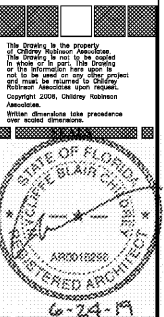
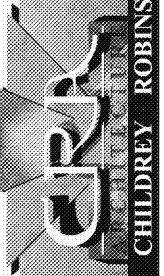

REV.	DESCRIPTION

06-24-2019

PIER DETAILS

A-100.1